

# The Clear Wave Uni-pivot Tonearm

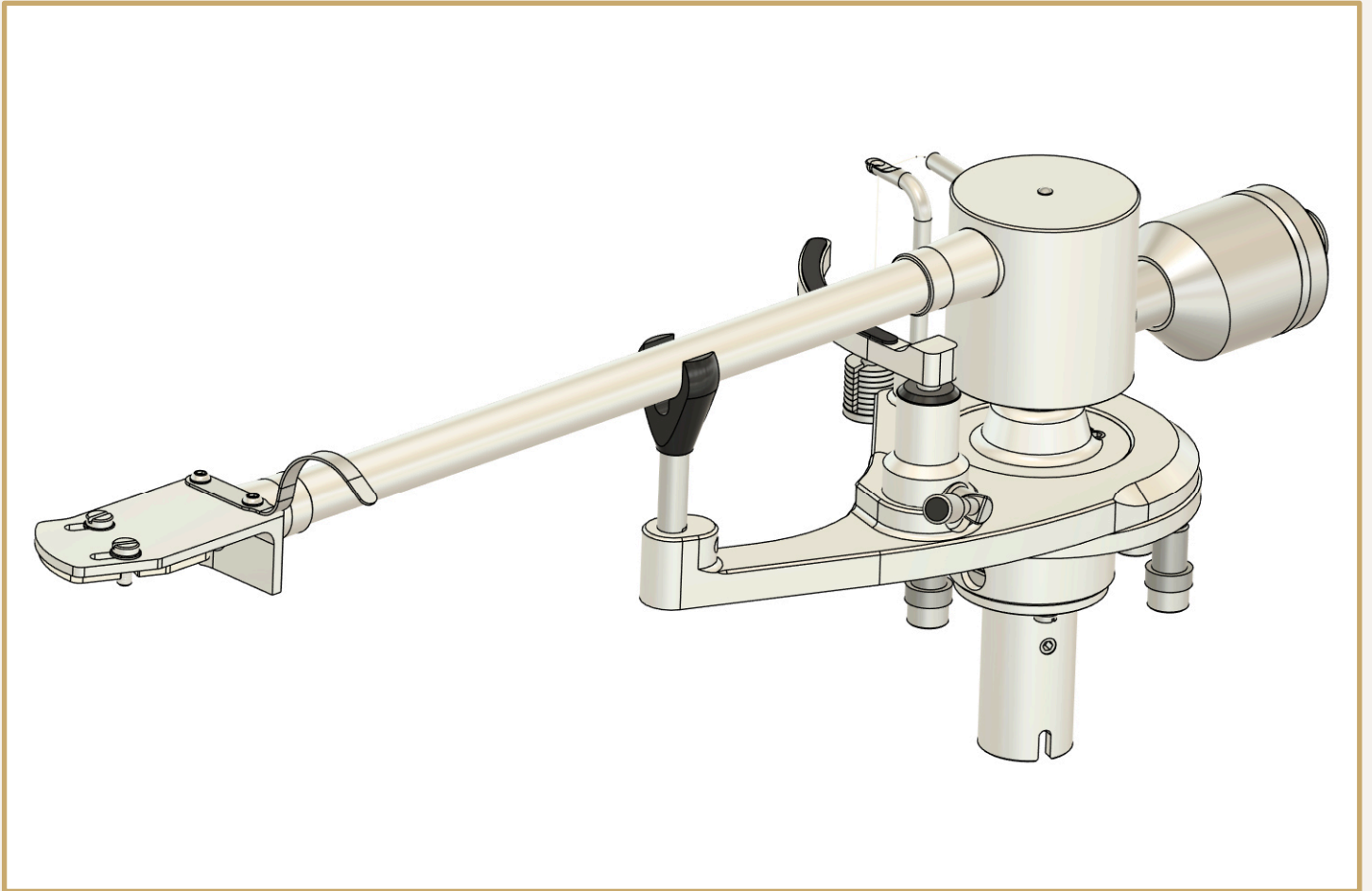

## User Manual & Set-up

## Introduction

Thank you for purchasing this Uni-pivot Tonearm. Our motivation for making this arm was that we wanted a Uni-pivot arm similar to the original Aro Tonearm by Naim. This arm follows same design principles to the Aro with some enhancements to improve usability. We are confident you will get as much pleasure from using it as we have from its design and manufacture.

It is important to read and follow the instructions in this manual as a certain amount of assembly and set-up is required to achieve the best performance from this Tonearm. Unlike earlier designs that required special fittings, this arm is engineered to mount directly onto a Linn Sondek LP12 using the standard Linn arm board, offering greater flexibility and an easier installation.

If for any reason you don't feel confident to set this arm up on your LP12 then there are dealers who have specialised equipment to work on Linn LP12 decks, who could do the work for you.

## Guarantee

This Bool Audio Tonearm is manufactured in Great Britain and is guaranteed for **two years** against defects in materials and construction. This doesn't include damage due to accident, misuse or incorrect installation. If you do have any problems please contact us quoting the serial number of the Tonearm which you will find on this page of the manual.

We are fully committed to the idea of **right to repair**. If you have any problems after the guarantee period or problems outside of the guarantee we are able to supply you with any spare parts you may require. This doesn't apply while in the guarantee period, where the arm must be returned to us for repair.

## Tonearm Serial Number

## Important

The tonearm is a precision instrument and care must be taken in handling especially when placing the arm on the jewel bearing. If cleaning is necessary use warm soapy water, don't use alcohol or similar solvents and/or abrasives.

---

## Kit Contents

Please check the contents of the tonearm kit. *Figure 1* shows the contents of the kit box with the parts divided into sub-assemblies. These sub-assemblies will require further assembly using the tools provided. Please familiarise yourself with the parts by referring to the pictures below, along with the actual parts in your kit. There are also drawings in Appendix 2 you may refer to.

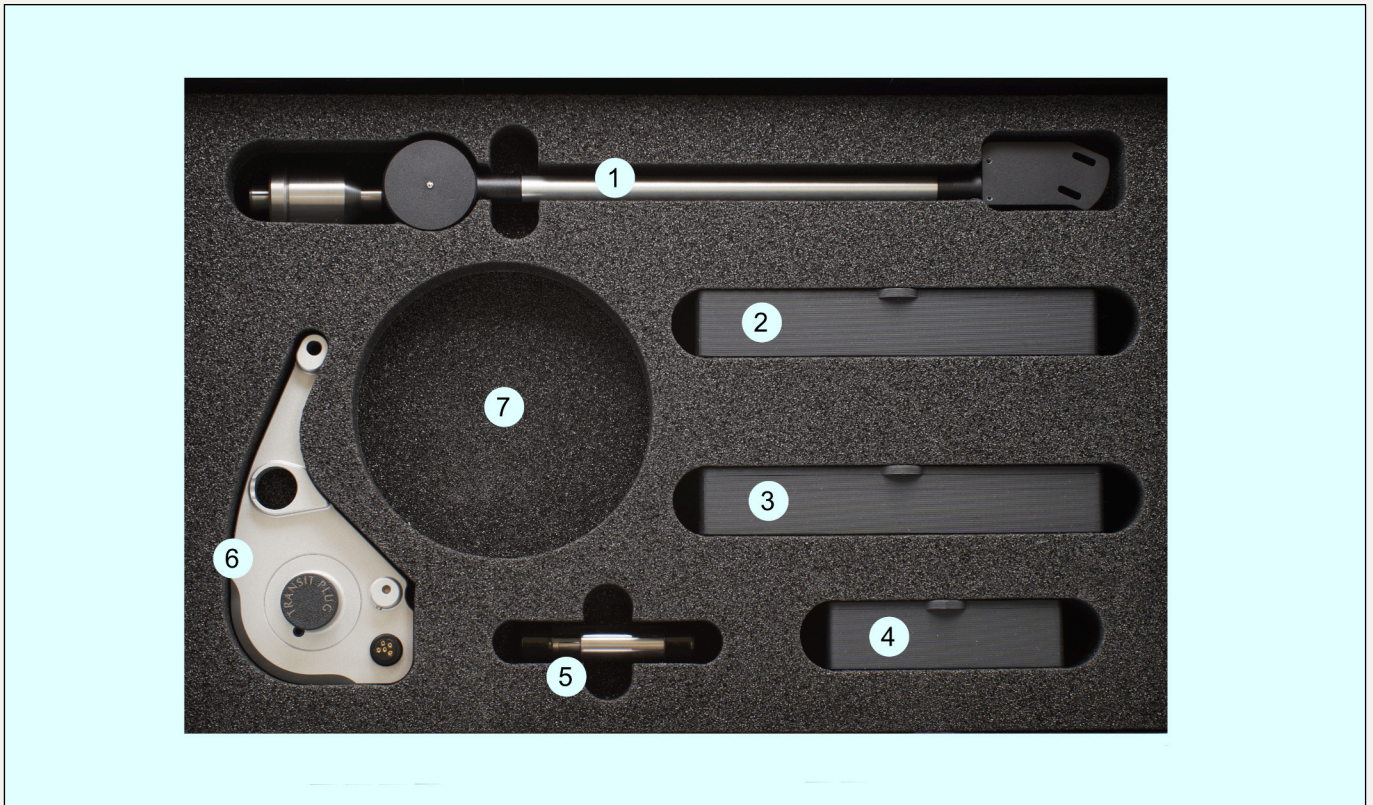

*Figure-1: Arm kit box*

### Parts Identification

- 1. Arm assembly**
- 2. Assembly tools kit box**
- 3. Small parts kit box**
- 4. Tonearm lift kit box**
- 5. Uni-pivot assembly with sapphire bearing**
- 6. Main arm mounting assembly**
- 7. Space for Tonearm cable** (if ordered at the same time as the Tonearm)



Figure–2: ToolKit Box.

ToolKit box contents.

1. 2mm Flat Screw Driver
2. Tweezers
3. 3.0mm Allen Key
4. 2.0mm Allen Key
5. 1.5mm Allen Key
6. Tool for tightening tracking arm

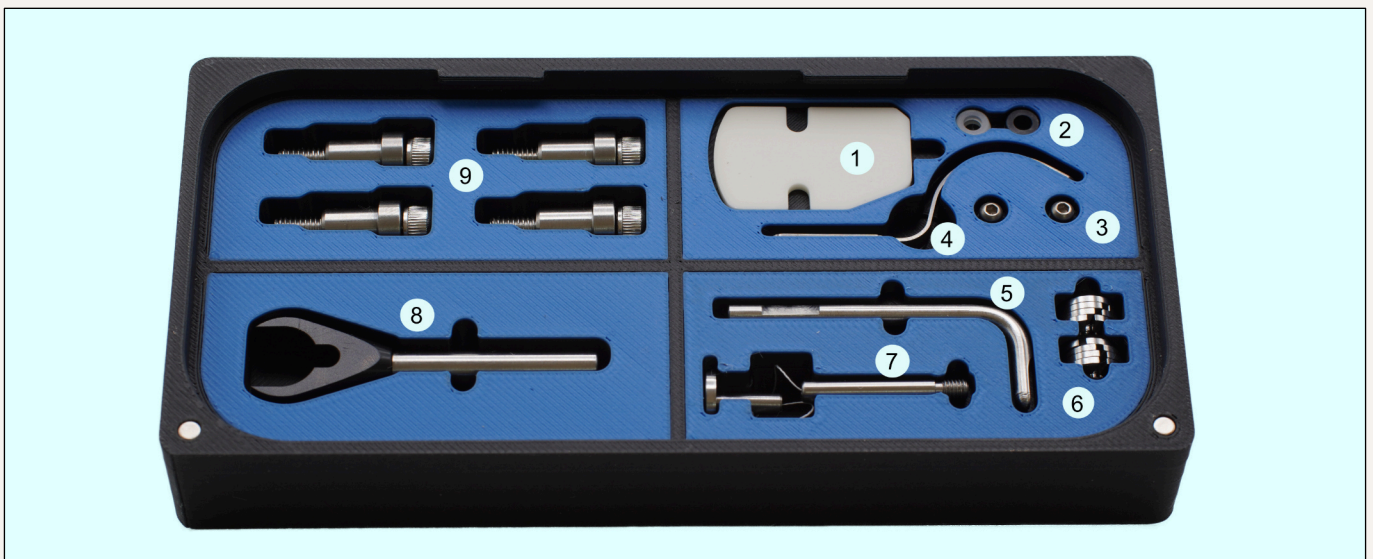

Figure–3: Small Parts Kit Box.

---

*Small Parts Kit Contents*

1. **Ceramic spacer for head shell**
2. **Soft washers for cartridge screws (to prevent damage to the head shell)**
3. **Finger Lift screws**
4. **Finger Lift**
5. **Anti-skate weight carrier arm**
6. **Anti-skate adjustment weights (8 pieces)**
7. **Anti-skate arm and weight carrier**
8. **Tonearm rest support**
9. **Mounting Screws and Special washers (4 pieces)**

Use the tweezers from the tool kit to remove components from the kit box.



Figure-4: One Arm Lift Kit Box

*Arm Lift Kit Contents*

1. **Piston Assembly**
2. **Arm Rest**



Figure-5: Sapphire Bearing Pivot Assembly.

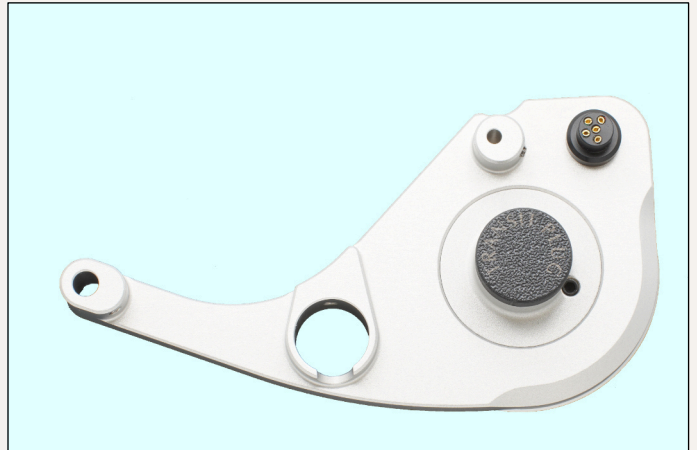

Figure-6: Arm Mounting Assembly.



Figure-7: Arm Assembly.



Figure-8: Tonearm alignment Tool

## Tonearm Assembly.

In order to get the best results from your new Uni-pivot Tonearm the deck must be correctly set and levelled, and must have a standard Linn Arm-board.

First we need to assemble the Tonearm mounting and Tonearm itself. We will need to go through the following steps. To complete this you will need access to the underside of the turntable. If you have one, place the turntable on a setup stand and remove the bottom plate. If you don't have one you will need to improvise but **do not** turn the deck upside down as this could cause problems with the platter suspension. Remove the current arm and then take the Main Arm Mounting Assembly (*Figure 6*) and Mounting Screws (*Figure 3, Part 9*).

### *Tonearm Assembly Step-1*

Arrange the Main Arm Mounting Assembly on the arm board in the orientation as shown below in *Figure 9*.



*Figure-9: View showing orientation of Main Arm Mounting Assembly on the arm board (the front of the deck is to the left).*

Fit the four screws together with the special washers. Do not overtighten. Tighten the screws until they are finger-tight, then apply an additional 30–35° rotation using the Allen key (see *Figure 10*). This corresponds to approximately 70 mm of movement at the end of the 3 mm Allen key from the tool kit. See Appendix 1 for a diagram.

While underneath the turntable, attach the plug to the connector on the bottom of the Arm Mount Assembly. (The plug shown in *Figure 10* may not look exactly like yours; this is a Boolaudio plug)



Figure–10: Showing fixings of Main Arm Mounting Assembly.

### Tonearm Assembly Step–2

Attach the Arm Rest (Figure 3, Part 8) and the tracking weight support arm (Figure 3, Part 5), to the Main Arm Mounting Assembly (see Figure 11). Use the 2mm flat screwdriver from the tool kit. Ensure the clamp screws are tightened against the orientation flat on these parts to guarantee correct alignment. Position these as low as possible, the height can be adjusted later.



Figure–11: Showing fixing screw positions for the Anti-Skate weight arm and Tonearm support. Use the 2mm screwdriver from the tool kit.

*Tonearm Assembly Step –3*

Next attach the Tonearm Lift piston to the Tonearm rest. The clamp screw on the arm must engage with the flat on the Tonearm Lift piston. See *Figure 12* circled details.

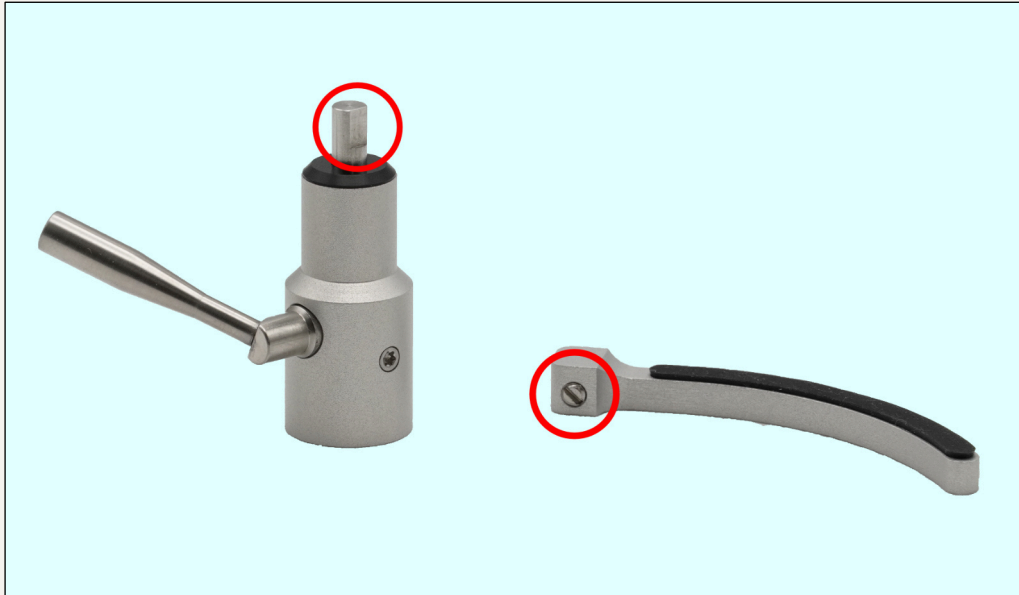

*Figure–12: Tonearm Lift Parts - Fixing screw and orientation flat shown circled. Use the 2mm screwdriver from the tool kit.*

*Tonearm Assembly Step –4*

Next, attach the Arm Lift Assembly in its lowest position on the Arm Mounting Assembly (see *Figure 13*). The clamping screw must tighten against the orienting flat (do not over tighten); the final height will be adjusted later.

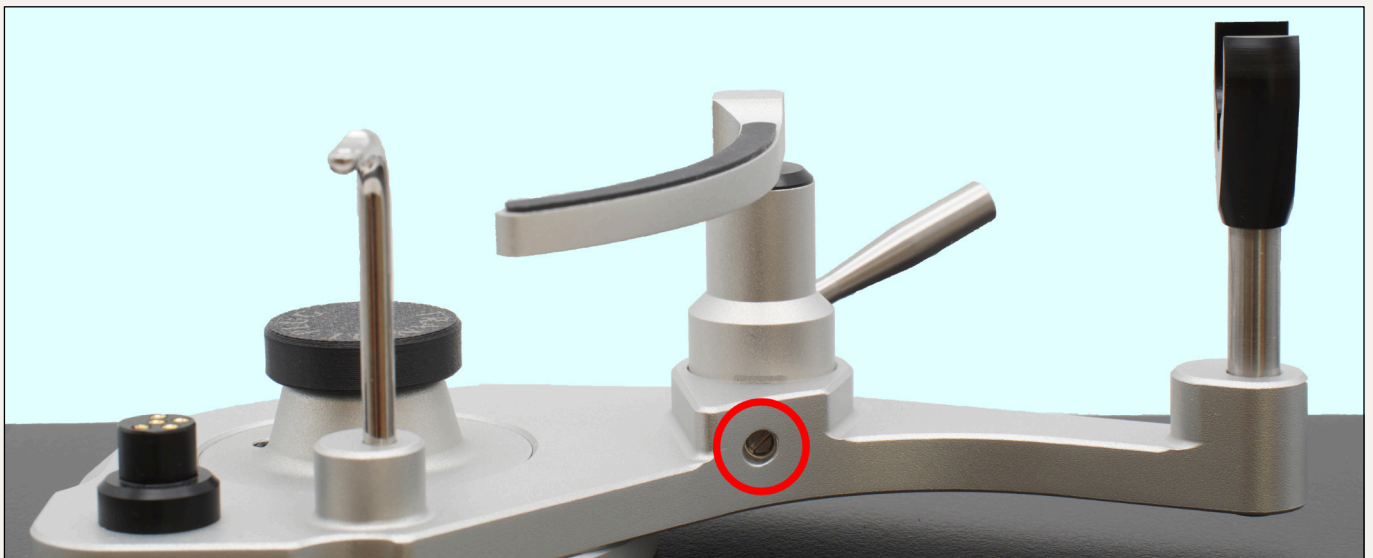

*Figure–13: Initial fitting of Tonearm lift - clamping screw circled against orientation flat. Use the 2mm screwdriver from the tool kit.*

*Tonearm Assembly Step –5*

The next part to install is the Sapphire Bearing Pivot Assembly (see *Figure 5*) which attaches to the Main Arm Mounting Assembly. First, remove the transport plug by slackening the clamping screw (circled red in *Figure 14*) using the 2 mm Allen key from the tool kit. Avoid moving the assembly while the transport plug is removed, as small clamp part could shift out of position. If this occurs use the 2 mm Allen key reposition the clamp parts correctly. Install the pivot assembly as shown (see *Figure 15*) ensuring the scale is visible. This will be useful later when adjusting the height of the Tonearm. Do not overtighten the clamp screw. Tighten it only until the Pivot Assembly no longer drops under its own weight. Then rotate the Allen key a further 13–16°, which equates to approximately 25 mm of movement at the end of the key. See Appendix 1 for a diagram.

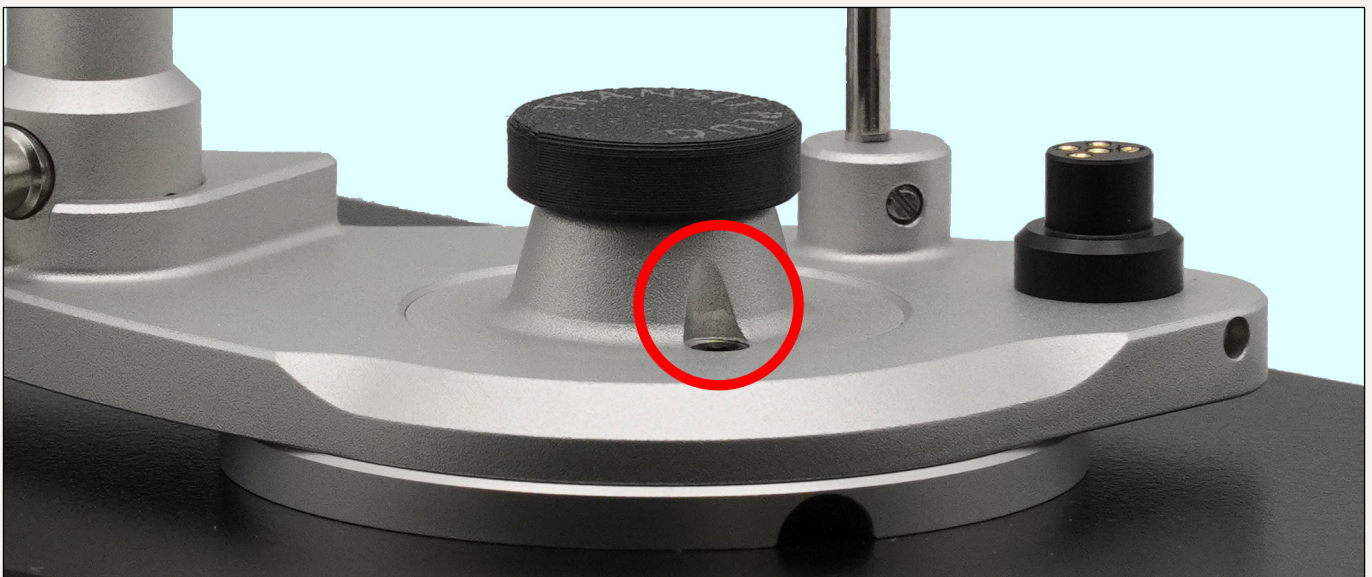

*Figure–14: Pivot Assembly Clamp Screw Position. (Note also the transport plug)*



*Figure–15: Pivot Assembly Initial Fitting.*

*Tonearm Assembly Step – 6*

The next part to install is the Anti-skate Weight Arm and Weight Carrier (see *Figure 3, Part 7*). The parts are screwed into the body of the tonearm (see *Figure 16*).



*Figure–16: Fitting of Anti-skate weight arm.*

The Anti-skate Weight Arm and Weight Carrier are attached to each other by a fine cord; **do not** pull them apart. Take the Tonearm and the Tracking Weight Arm and screw it fully into the tapped hole in the Arm body as shown circled in *Figure 16*. Tighten with the tool from the tool kit (see *Figure 2 - Part 6*). Do not use pliers or similar tools as this may damage the weight arm (see *Figure 17*). Remove tool when Weight Arm is tightened. Do not add any weights at this point.

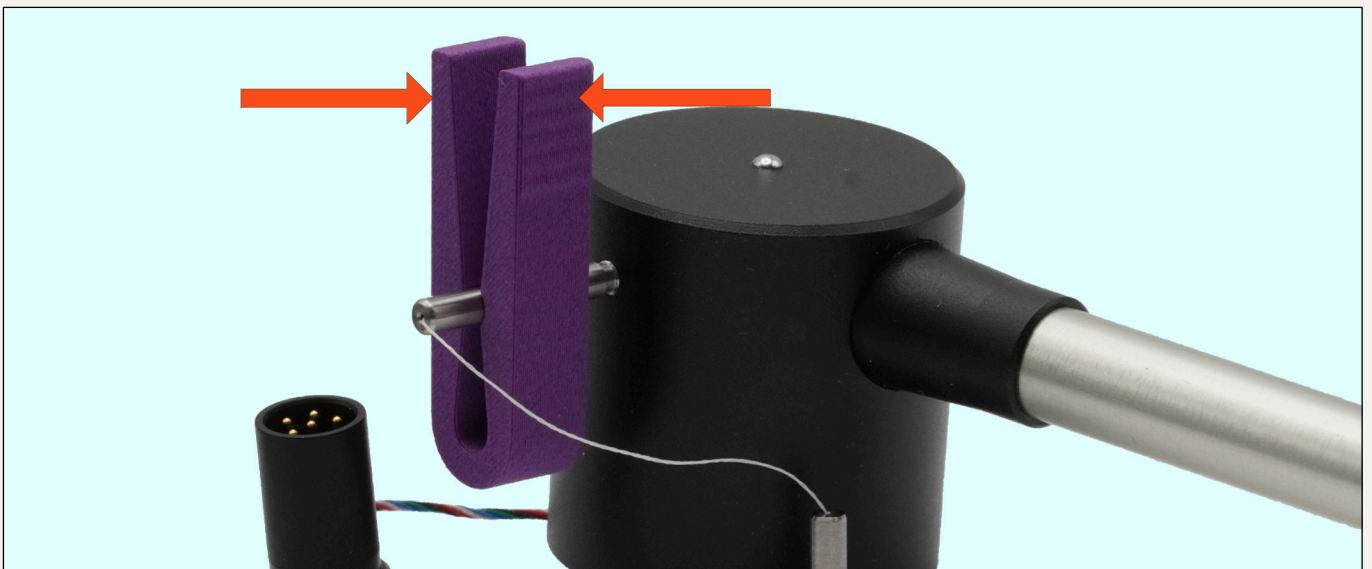

*Figure–17: To grip Weight Arm when tightening use the special tool from the tool kit and grip as arrows show.*

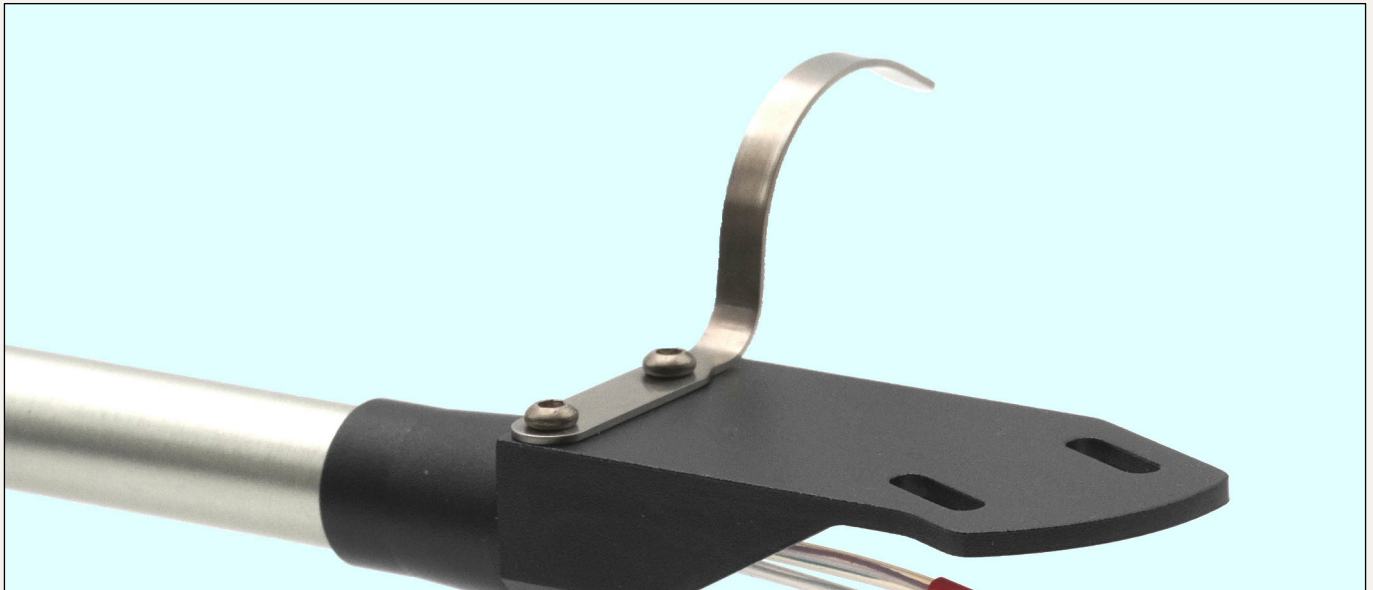

*Figure–18: Orientation and fitting of Finger Lift.*

#### *Tonearm Assembly Step–7*

Next attach the Finger Lift (*Figure 3, Part 4*) using the M2 screws (*Figure 3, Part 3*) supplied with the finger lift, and the 1.5mm Allen key from the toolkit (see *Figure 18*). Note the orientation of the Finger Lift.

#### *Tonearm Assembly Step–8*

At the other end of the Tonearm we need to remove the plastic transport protection ring (orange, see *Figure 19*). To do this, simply pull the weight off the weight arm. The weight is a push fit secured by a pair of O-rings. Remove the protector, then re-position the weight about mid way along the arm, aligning the engraved marks (see *Figure 20*). Final adjustment will be made later when we balance the arm.



*Figure–19: View showing transport protection ring*

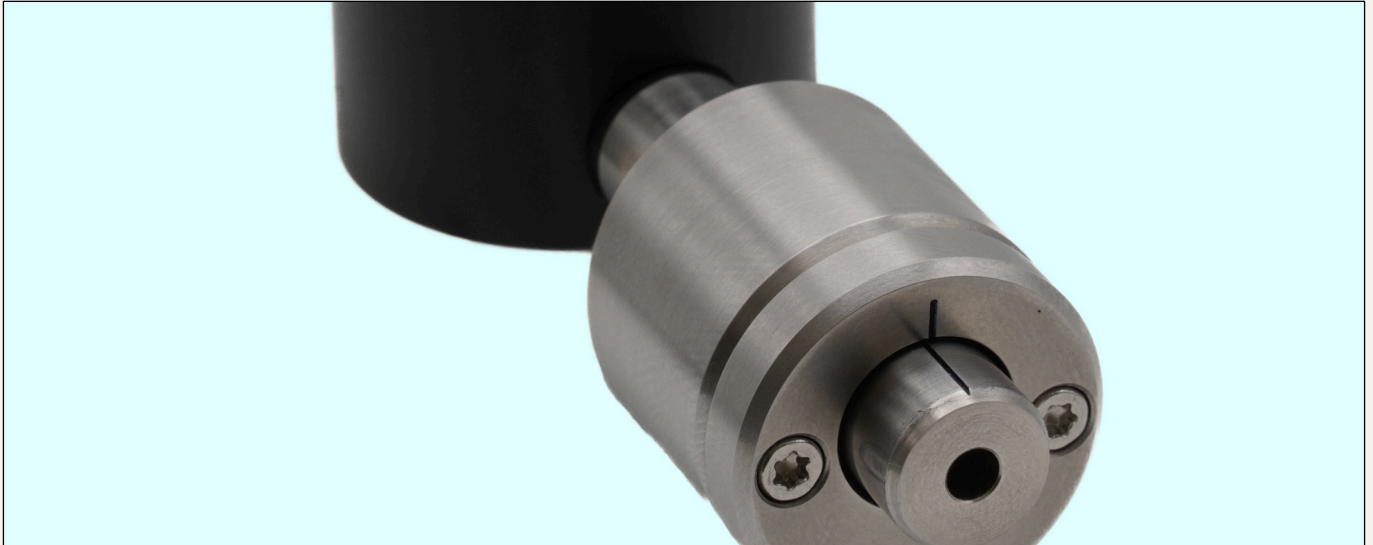

*Figure–20: After removal of transport ring and re-alignment azimuth adjustment engraved marks.*

#### *Tonearm Assembly Step –9*

Next, fit your cartridge to the tonearm. Take the tonearm and phono cartridge, then attach the four colour-coded wires to their respective pins, using the tweezers from the tool kit if necessary. Ensure the plugs are fully seated (see *Figure 21*). Then attach the cartridge to the tonearm using the white ceramic spacer (*Figure 3, Part 1*), the plastic protective washers (*Figure 3, Part 2*), and the cartridge screws. Please note, the plastic protective washers are optional, and provided only to prevent damage to the headshell. The same applies to the ceramic spacer, you may omit it if you wish, although we believe it helps overall sound quality. Ensure the cartridge stylus guard is in place during this process. Do not overtighten the screws, as the positioning at this stage is approximate and will be refined later. The assembly is now largely complete and you can proceed to the setup stage.

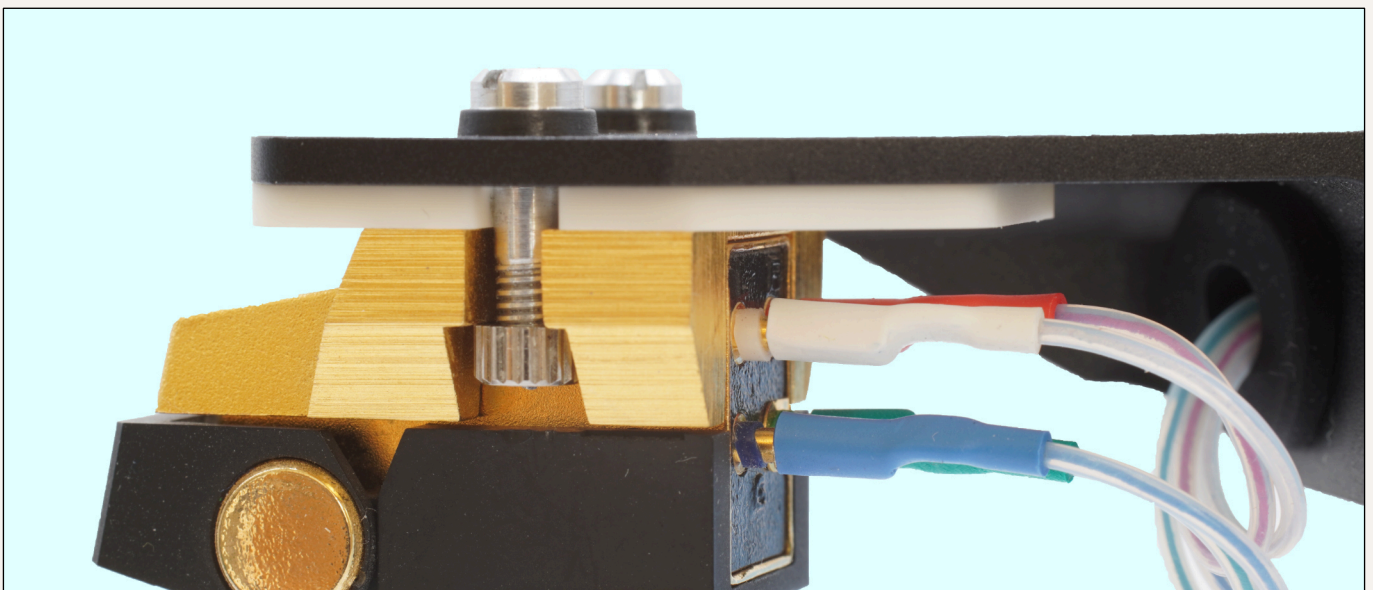

*Figure–21: View showing cartridge fitted with ceramic spacer.*

### Tonearm Set-up

In this section we will align the various parts of the tonearm and finish the assembly.

#### Setup Stage -1.

First, we need to place the arm in position on its bearing. The sectional view in *Figure 22* shows the arrangement. Ensure the pivot (1) is in the pivot bearing cup (2). When correctly in position the arm will float without any friction.

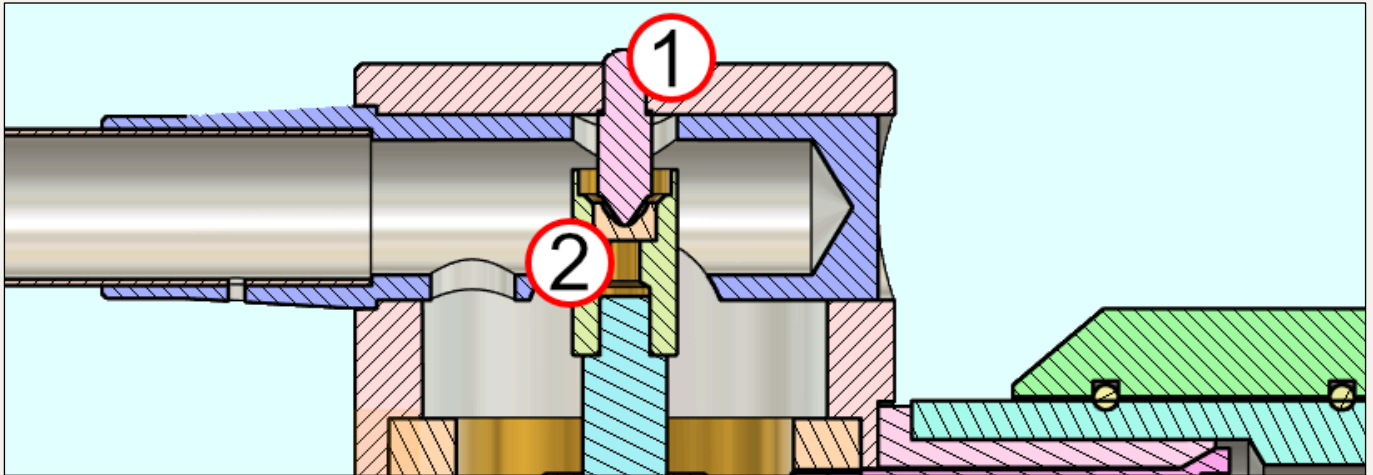

*Figure-22: Sectional view of uni-pivot.*

Next, fit your cartridge into its correct position. Looking at available data we believe the original tonearm was likely set up to the Baerwald scheme. This scheme sets the null point radius (where the alignment is exact) to an inner radius at 66mm and the outer radius at 120.9mm. To assist with this we have supplied a tonearm set-up Jig for this geometry (see *Figure 8*). The cartridge is moved so the stylus is coincident with the spot in the middle of the set-up grid. *Figure 23* shows the outer set-up grid. Then, align the sides and/or the front of

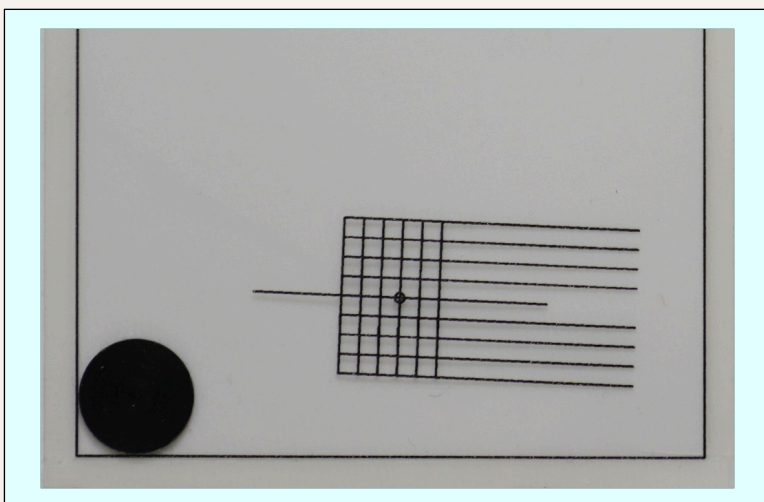

*Figure-23: Close-up of set-up grid*

the cartridge with the grid. Alignment is easier if one of the cartridge screws is very lightly nipped while the other is loose, enabling it to pivot slightly. Then, nip the other screw and loosen the other allowing you to pivot closer to the ideal position. Once the position is correct check with the inner alignment grid and if all is well this should also be in alignment. If not, try to balance any error between the two positions. Once satisfied, finally tighten both screws.

---

### Setup Stage -2.

Next, we will set up the tracking weight (or tracking force). The correct value should be specified by your cartridge manufacturer — this is usually in the range of 1.5 to 3 grams. You will need a set of scales (see *Figure 24*) which are readily available from hi-fi suppliers or from ourselves.



*Figure-24: Arm tracking force scales*

Place the stylus on the scales to read the tracking force. At this stage, it is unlikely to be correct. **Before making adjustments, lift the arm off the bearing to avoid any damage.** If the tracking force just measured is too low, move the balance weight towards the pivot; if it is too high move it away. Keep the azimuth adjustment marks aligned for now. Repeat this check and adjustment until you have the correct tracking weight.

### Setup Stage -3.

We now need to check the VTA (Vertical Tracking Angle). For this we will use a gauge, as shown in *Figure 25*. These are obtainable from good hi-fi retailers or from ourselves. To do this, place an old record on your deck and position the arm in a convenient location. Look through the gauge and compare the horizontal parallel lines to the tonearm. The tonearm should be parallel to these lines (see *Figure 26*). For good results your eye-line should also be parallel to the surface of the record. If the Tonearm near the pivot looks higher, the pivot height needs to be reduced; or if lower, it needs to be raised. *Figure 15* shows a scale on the Sapphire Bearing Pivot Assembly that you can use to help with adjustment. A certain amount of trial and error is involved when adjusting the height. Initially move the pivot up or down one full division by slackening the clamp screw (see *Figure 14*). Hold the pivot while doing this to prevent it from dropping down to the lowest point and losing the current position. Tighten the clamp screw, replace the arm, and check for parallelism again. Repeat until the arm is correctly aligned.

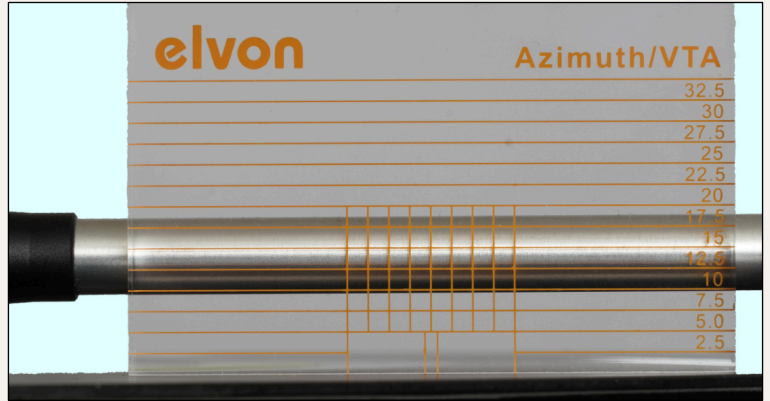

Figure-25: Azimuth and VTA Gauge.

Figure-26: Sighting for parallelism (VTA).

Setup Stage -4.

Now we will set the azimuth. Place the azimuth and VTA gauge in front of the arm and cartridge, as shown in Figure 27. We will be using the vertical lines on the gauge for this check. With your eye-line parallel to the record, check that the sides or top of your cartridge are parallel to the lines on the gauge. If there is any misalignment, rotating the balance weight — while keeping its position — will correct the error. There is some trial and error involved in this adjustment. Rotating the weight one way will cause the azimuth to rotate slightly in the opposite direction. You can see how much adjustment you have made by referring to the engraved lines (see Figure 28). **Remember to lift the arm off the bearing before making any adjustment.** In most cases, only a small adjustment will be necessary.

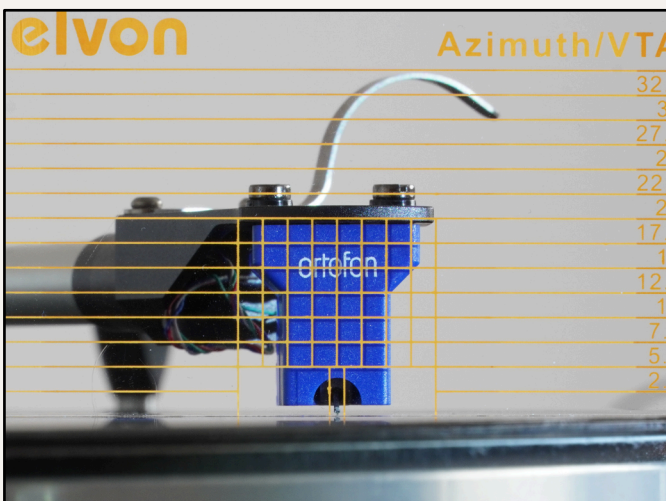

Figure-27: Sighting Tonearm for azimuth.

Figure-28: Rotate weight for adjustment of azimuth.

At this point, it is a good idea to check the tracking weight in case it has shifted during the azimuth adjustment. If it has, then reset the tracking weight and re-check all settings up to this point.

### Setup Stage -5.

The next stage is to set the height of the Tonearm Lift. Place the arm in a convenient position on a record and check the gap between the arm and the lift's rubber pad (see *Figure 29*). This gap should be approximately 1.5–2.0 mm. *Figure 12* shows the position of the clamp screw. When adjusting this height, it is important to remove the Tonearm to prevent damage to the bearing. Next set the Tonearm Rest. *Figure 11* shows the clamp screw for this. While this setting is not critical aim to adjust it so the rest supports the arm in a position roughly parallel to the surface of the record.

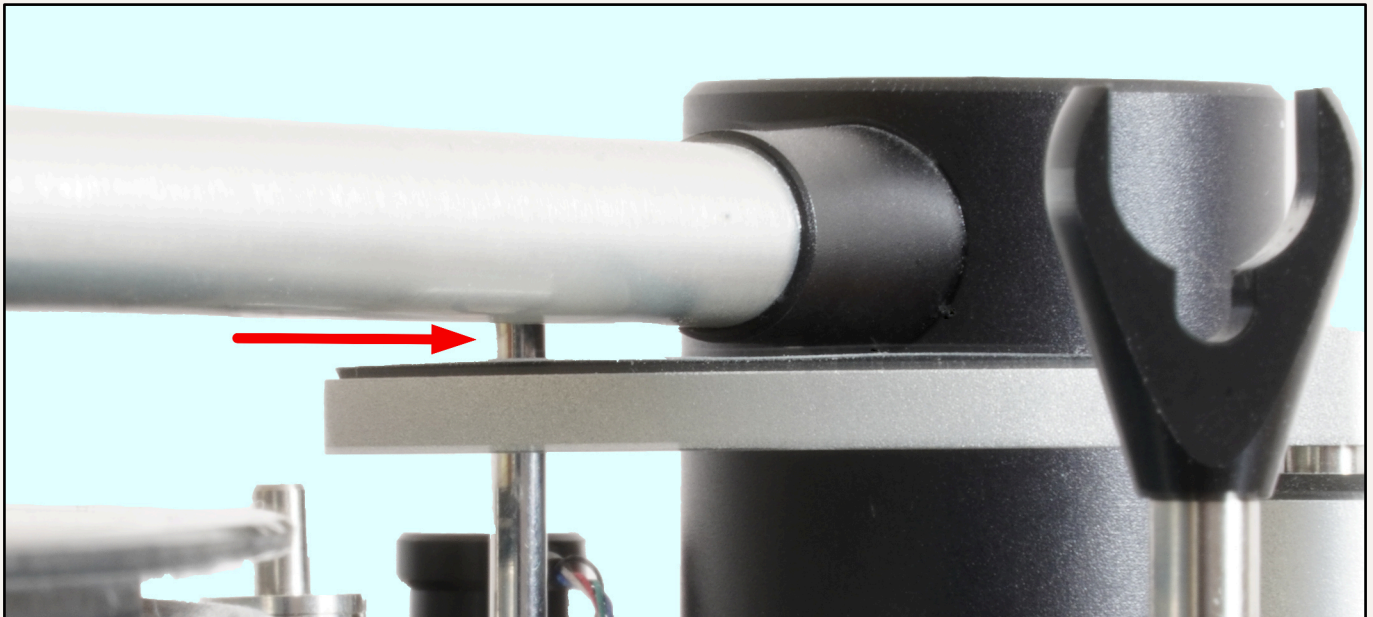

*Figure–29: Arm Lift setting gap - Aim for 1.5-2.0 mm*

### Setup Stage -6.

The next stage is to set-up the anti-skating mechanism. First, we will set the height of the anti-skate carrier arm. To do this, begin by putting the anti-skating cord into place. This passes through the slot in the anti-skate anchor arm (see *Figure 30*). At this stage, do not place any weights on the weight holder. We are now ready to adjust the height. With the arm positioned on a record, ensure the cord (see *Figure 31*) is parallel to the baseboard. This is achieved by raising or lowering the carrier arm as needed. *Figure 11* shows the location of the clamp screw. This adjustment ensures the anti-skate force is applied in the plane of the record, with no tendency to pull the arm upwards or downwards.



Figure–30: Fitting Anti-Skate Cord through slot in carrier arm.

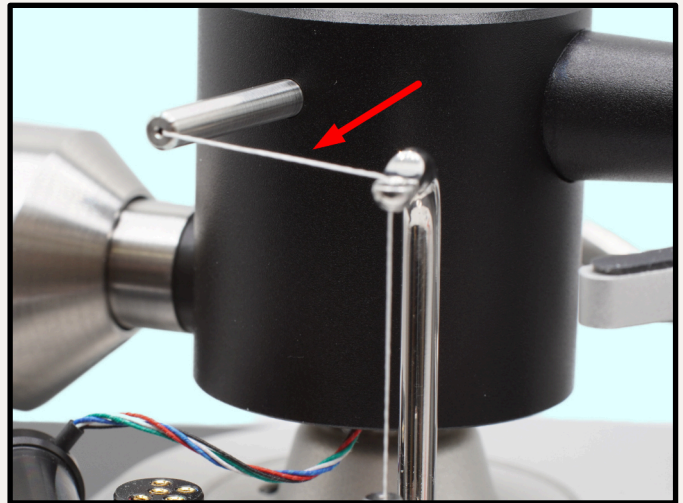

Figure–31: Cord (arrowed) align horizontally with base board.

Next, connect the miniature DIN plug (see Figure 33). This should be done now, as the best method we have found for setting the anti-skate weight is by listening to a test record. We recommend the Ortofon test record. (see Figure 32).



Figure–32: Recommended Ortofon test record.



Figure–33: Miniature special DIN plug

The DIN plug is a simple push fit. Align the pins and press it firmly into the socket. If you have trouble aligning the plug, place it onto the socket and slowly rotate the plug until you feel the pins drop into place, then press fully home. (see Figure 34).

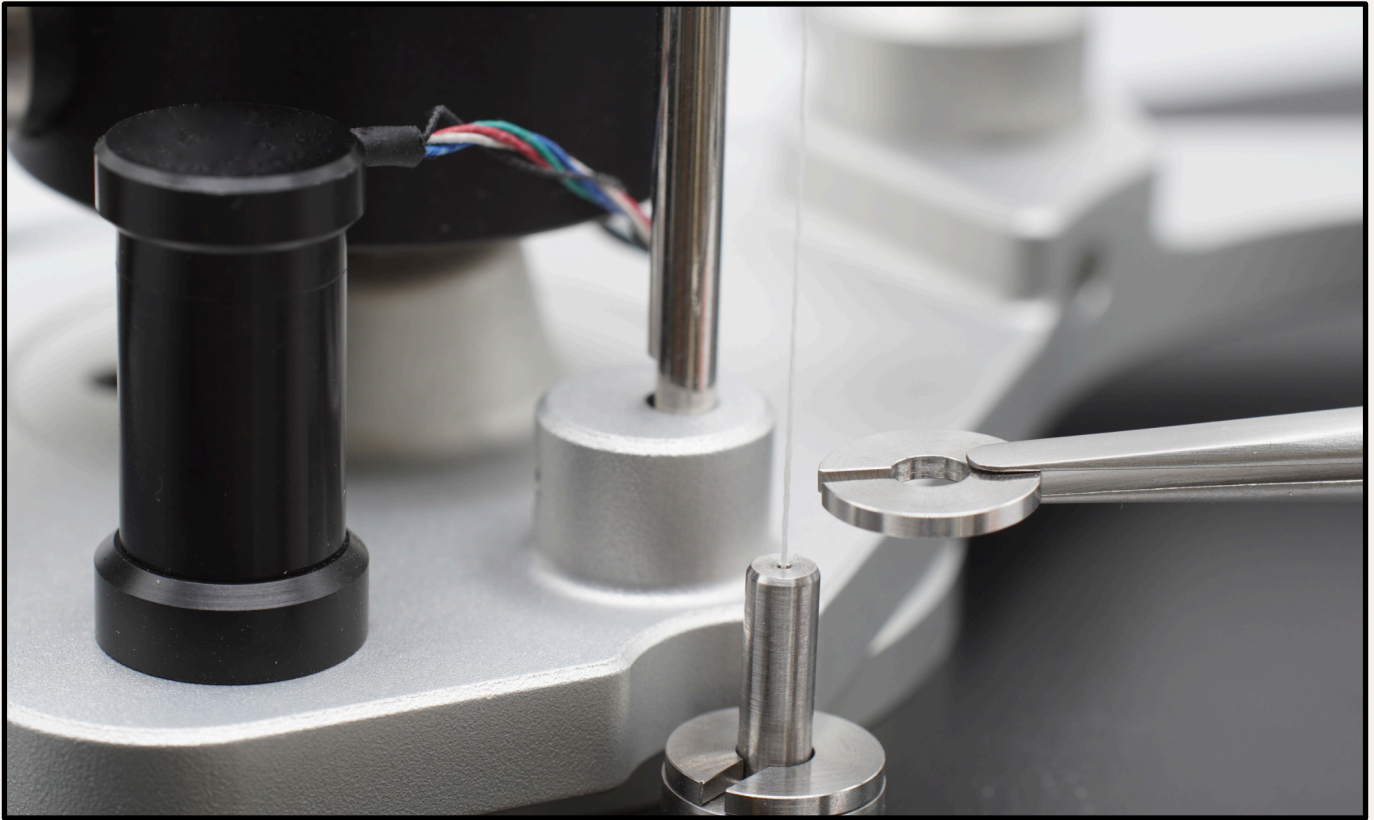

*Figure–34: Assembled DIN plug and placing Anti skate weights onto weight carrier.*

## Final Adjustment – Setting the Anti-Skate Weight

The anti-skate weight is set by playing the test record and listening for distortion in the left and right channels. If you are using the Ortofon record the relevant tracks are 9–14. Most cartridges will not track all these without distortion, but many will track the first four (tracks 9–12) it depends on your cartridge.

Begin by playing the record from track 9 onward, with no weights on the weight carrier, until you hear distortion in one of the channels. Place a weight on the carrier (see *Figure 34*), and play the tracks again. When distortion reappears, it is likely to be at the next track along.

At some point, after adding weights, the distortion will either shift to the opposite channel or be heard in both channels. If distortion is heard both, then you have reached the tracking limit of your cartridge. If the distortion shifts to the other channel then remove the most recent weight — you have now reached the optimal anti-skate setting.

Your new tonearm is now fully set up.

Appendix 1 - Torque Diagrams

Here are diagrams to help correctly tighten screws when assembling the tonearm.

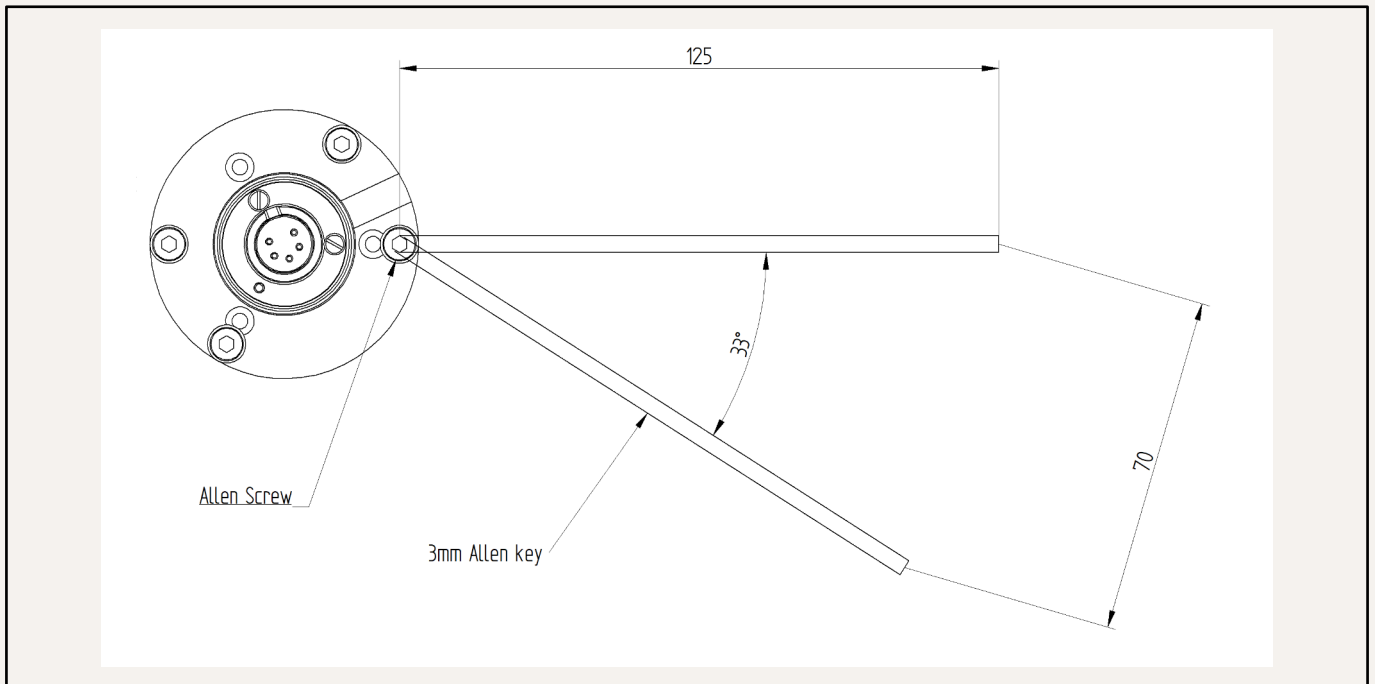

Figure-35: Mounting screw tightening.

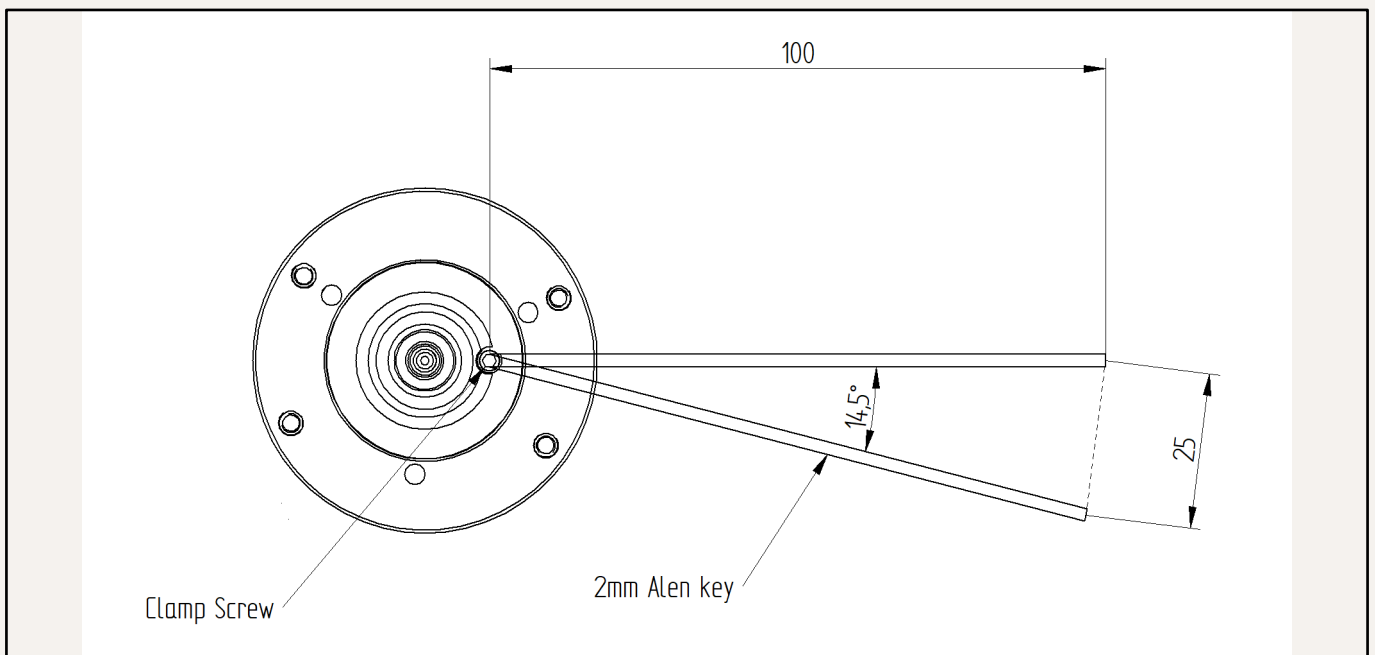

Figure-36: Bearing clamp screw torque.

## Appendix 2 – Assembly Drawings

This Appendix contains assembly drawings of the tonearm. These are provided to help clarify the various parts and their relationships within the assembly.

If you require replacement parts, the drawings include part numbers for ordering. Please note that not all components are available individually. Some parts can only be supplied as pre-assembled units. For example, the tonearm headshell, tube, and main body are bonded together and must be aligned using a jig, and are therefore only available as a complete assembly.